

COOKOLOGY

TCH301 30cm Ceramic Hob Black Instruction manual

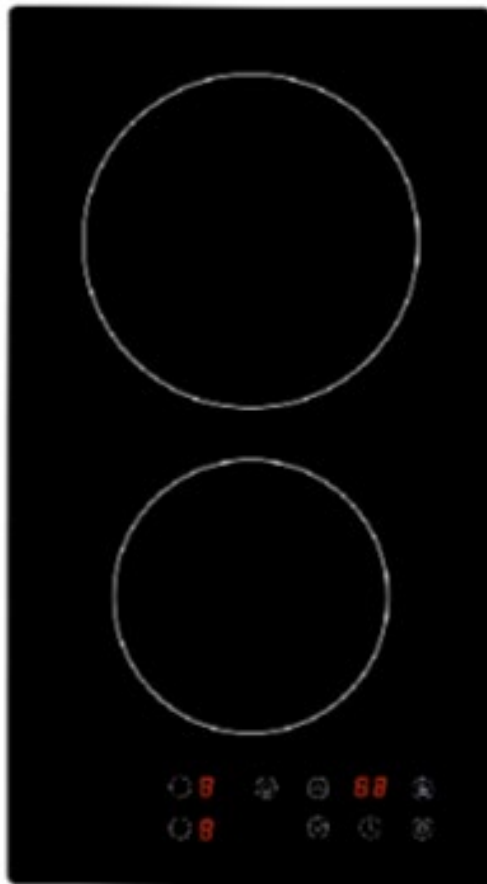

CONTENT

1.....	Notice
2.....	Installation
3.....	Description of the Ceramic hob surface layout
4.....	Using the ceramic hob
5.....	Hob guidelines
6.....	Maintenance and cleaning
7.....	Environmental note

1. Notice



Caution!

- Do not use the ceramic hob until you have read this instruction manual. The ceramic hob is intended for household use only.
- The appliance becomes hot during operation. Take care not to touch the hot surface.
- Always keep children away from the ceramic hob.
- While in operation direct contact with the ceramic hob may cause burns!
- Ensure that small items of household equipment, including connection leads, do not touch the hob as the insulation material of this equipment is usually not resistant to high temperatures.
- Do not leave the ceramic hob unattended when frying. Oils and fats may catch fire due to overheating or boiling over.
- Do not switch on the hob until a pan has been placed on it.
- Do not put pans weighing over 25kg on the hob.
- Do not use the ceramic hob in the event of a technical fault. Any faults must be fixed by an appropriately qualified and authorized person.
- In the event of any incident caused by a technical fault, disconnect the power and report the fault to the service centre to be repaired.
- The rules and provisions contained in this instruction manual should be strictly observed. Do not allow anybody who is not familiar with the contents of this instruction manual to operate the ceramic hob.
- The ceramic hob should not be cleaned using steam cleaning equipment.
- **IMPORTANT:** The adjacent furniture or housing and all materials used in the installation must be able to withstand a minimum temperature of 85°C above the ambient temperature of the room it is located in, whilst in use.
- Any damage caused by the appliance being installed in contravention of this temperature limit, or by placing adjacent cabinet materials closer than 4mm to the appliance, will be the liability of the owner.
- This appliance complies with all current European safety legislation. We do wish to emphasize that this compliance does not remove the fact that the appliance surfaces will become hot during use and retain heat after operation.

Child Safety

- We strongly recommend that babies and young children are prevented from being near to the appliance and not allowed to touch the appliance at any time.

- If it is necessary for younger family members to be in the kitchen, please ensure that they are kept under close supervision at all times.

General Safety

- Children less than 8 years of age shall be kept away unless continuously supervised.
- This appliance can be used by children aged from 8 years and above and persons with reduced physical, sensory or mental capabilities or lack of experience and knowledge if they have been given supervision or instruction concerning use of the appliance in a safe way and understand the hazards involved. Children shall not play with the appliance. Cleaning and user maintenance shall not be made by children without supervision.
- NEVER try to extinguish a fire with water, but switch off the appliance and then cover flame e.g. with a lid or a fire blanket.
- WARNING: Danger of fire: do not store items on the cooking surfaces.
- Means for disconnection must be incorporated in the fixed wiring in accordance with the wiring rules.
- Do not allow electrical fittings or cables to come into contact with areas on the appliance that get hot.
- Do not use the appliance to heat the room it is located in or to dry clothing.
- Do not install the appliance next to curtains or soft furnishings.
- If the supply cord is damaged, it must be replaced by the manufacturer, its service agent or similarly qualified persons in order to avoid a hazard.
- The appliance is not intended to be operated by means of an external timer or separate remote-control system.
- This product can be worked but not through outside timer and remote control.
- Warning: If the surface is cracked, switch off the appliance to avoid the possibility of an electric shock, the hob surfaces are ceramic glass or similar material which protect the live parts.
- Warning: a steam cleaner is not be used.
- CAUTION: The cooking process must be supervised. A short-term cooking process must be supervised continuously.
- WARNING: Unattended cooking on a hob with fat or oil can be dangerous and may result in a fire.
- This appliance should be connected to a circuit which incorporates an isolating switch which can accessible by the user after installation providing full disconnection from the power supply. The disconnection may be achieved by incorporating a switch in the fixed wiring in accordance with the wiring rules.

- Warning: Before obtaining access to terminals, all supply circuits must be disconnected.
- **WARNING:** Use only hob guards designed by the manufacturer of the cooking appliance or indicated by the manufacturer of the appliance in the instructions for use as suitable or hob guards incorporated in the appliance. The use of inappropriate guards can cause accidents.
- **WARNING:** The appliance and its accessible parts become hot during use.
- Care should be taken to avoid touching heating elements.
- Power cord will not be accessible after installation.
- For Installation instructions, please go to the section marked Installation.

2. Installation

Installing the ceramic hob

- The kitchen area should be dry and aired and equipped with efficient ventilation. When installing the ceramic, easy access to all control elements should be ensured.
- This is a Y-type design built-in ceramic, which means that its back wall and one side wall can be placed next to a high piece of furniture or a wall. Coating or veneer used on fitted furniture must be applied with a heat-resistant adhesive (100 °C). This prevents surface deformation or detachment of the coating.
- Hoods should be installed according to the manufacturer's instructions.

Assembly of ceramic hob :

- Make an opening with the dimensions given in the diagram for the hob to be mounted on the worktop.
- Check seal for perfect fit and overall cover. Lower the ceramic hob into place and align correctly.
- Using a standard screwdriver, tighten the tension clamps evenly starting at the centre and moving diagonal, until the built-in rim is tight on the worktop.

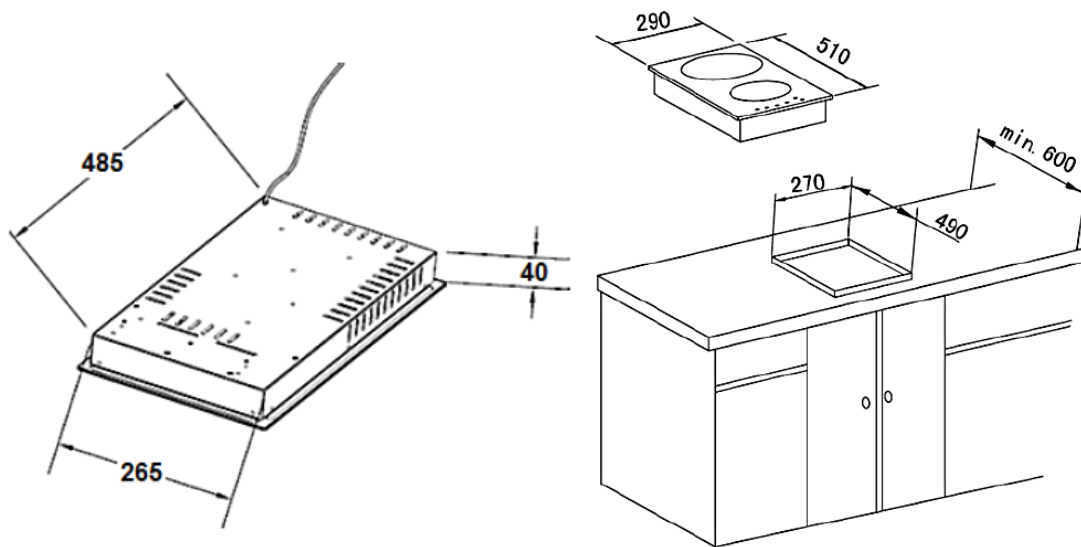

Cut a hole in the worktop that corresponds with the drawing shown above.

- **IMPORTANT:** You must observe the ventilation requirements shown in the drawing opposite.
- **IMPORTANT:** There are ventilation holes around the outside of the hob. YOU MUST ensure that these holes are not blocked by the work top, when you put the hob into position (see drawing opposite).
- **IMPORTANT:** Do not use a silicon sealant to seal the appliance against the aperture. This will make it difficult to remove the hob from the aperture in future, particularly if it needs to be serviced.

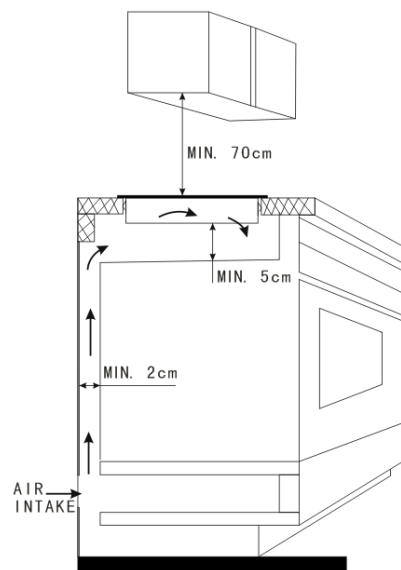

- Carefully turn the hob back over and then gently lower it into the aperture hole that you have cut out.
- There are holes on the base or the sides of the hob that you can fix the four brackets to. There are three holes in each one of the brackets.
- You should place the bracket on the underneath of the hob, in a position that is appropriate for the aperture that you have cut out. Using the screws provided, fix the bracket to the hob. These screws MUST be securely tightened.

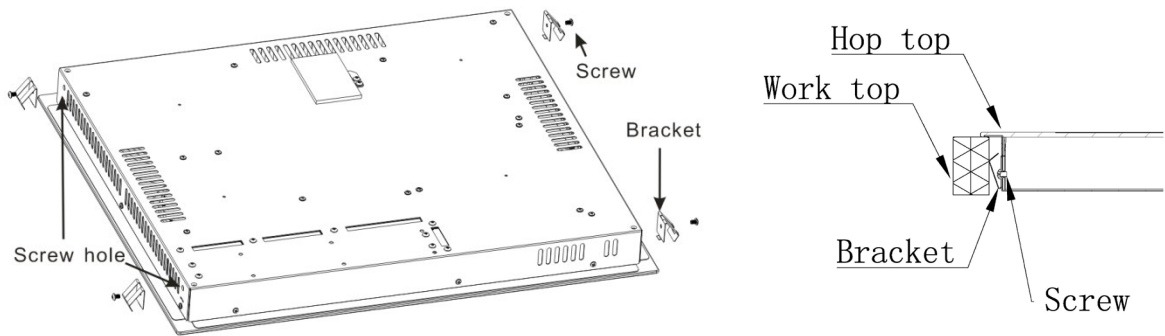

Fitting guidelines

The ceramic hob is manufactured to work with one-phase alternating current. The voltage rating of the ceramic hob heating elements is 220-240V. Adapting the ceramic hob to operate with two-phase current is possible by appropriate bridging in the connection box according to the connection diagram below. The connection diagram is also found on the cover of the connection box.

Remember that the connection wire should match the connection type and the power rating of the ceramic hob. The connection cable must be secured in a strain-relief clamp.

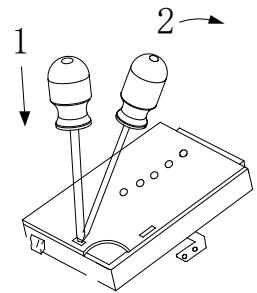

Replacing the mains supply cable

- ✧ If the mains supply cable is damaged, then it must be replaced by an appropriate replacement.
- ✧ The mains supply cable should be replaced in accordance with the following instructions:
 - Switch the appliance off at the control switch.
 - Open the terminal block on the underside of the hob.
 - Unscrew the terminal screws fixing the cable.
 - The “green-yellow” earth wire must be connected to the terminal marked \perp . It must be about 10 mm longer than the live and neutral wires.
 - The “blue” neutral wire must be connected to the terminal marked with letter (N) - the live wire must be connected to the terminal marked with letter (L).

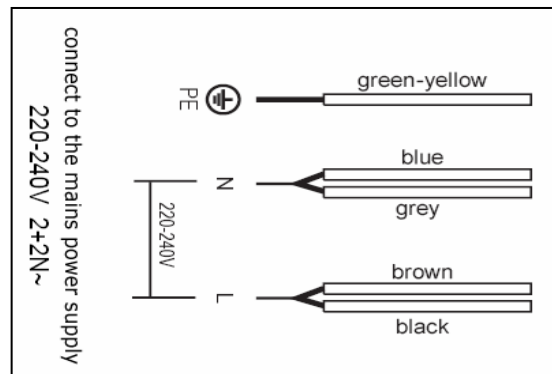

3. Description of the Ceramic hob surface layout

2 zone ceramic hob schematic diagram

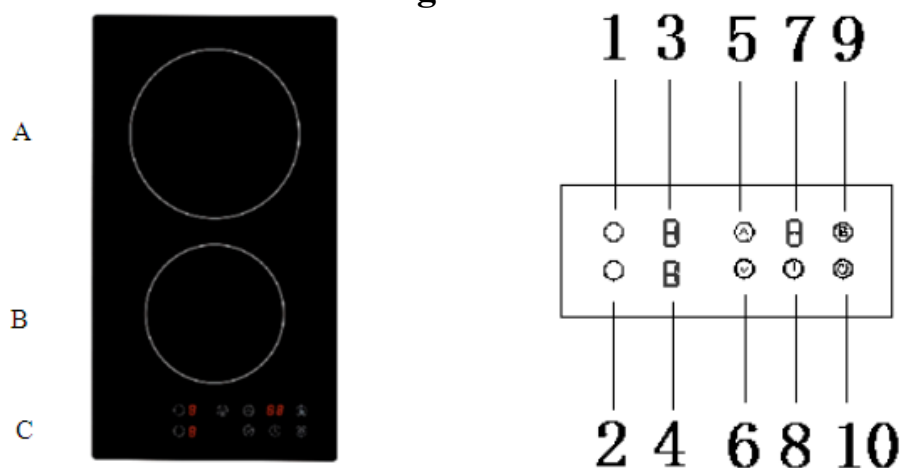

A Ø 200mm B Ø 165 mm

C Control panel

1. Sensor/rear cooking zone
2. Sensor/front cooking zone
3. Indicator/rear cooking zone
4. Indicator/front cooking zone
5. Plus-sensor
6. Minus-sensor
7. Indicator/timer
8. Sensor/timer
9. Key lock
10. ON/OFF sensor

4. Using the ceramic hob

Before first use



IMPORTANT: You should clean the ceramic hob surface (see “Maintenance and cleaning” section).

- ✓ You should switch on one cooking zone at a time, for 5 minutes at the maximum setting. This will help to eliminate any new smell that exists and evaporate any humidity that has formed on the heating elements during transit.
- ✓ Do not burn off more than one zone at once.
- ✓ You must place a saucepan filled half full with cold water on each zone as you burn it off.

Touch controls:

- ✓ All operations are performed by means of the touch controls that can be found on the control panel.

- ✓ Each touch control has a visual display that corresponds to it.

Switching the hob top on



- ✓ Press the ON/OFF button to switch on the appliance.
- ✓ The hob will beep once and all of the cooking zone indicators will light briefly, then go out.
- ✓ This means that the hob has entered stand-by mode.

Switching on a zone and setting a power level

IMPORTANT: A zone must be selected within 1 minute of switching the hob on.

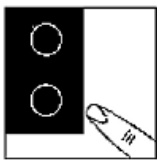

- ✓ Touch a cooking zone sensor.

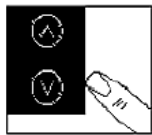

- ✓ Set the desired power level 1-9 using the Plus/Minus sensors. The corresponding indicator indicates the set power level.

Switching off a zone

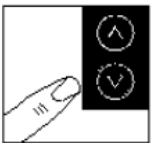

- ✓ Touch the corresponding cooking zone sensor and then the Minus sensor.
- ✓ Hold the Minus sensor until the indicator indicates 0. The cooking zone will be switched off after a few seconds automatically.

Switching off the hob

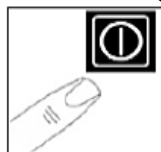

- ✓ Switch off the appliance as soon as you have switched off the cooking zones using the ON/OFF sensor.

Residual heat indicator

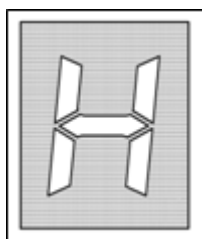

- ✓ When you have switched off a cooking zone, a flashing H is indicated on the corresponding cooking zone indicator (3/4). The temperature of such a cooking zone is more than 600 C. **RISK OF BURNS!**
- ✓ The H goes off as soon as the temperature is less than 600 C. □

- ✓ The H also goes off, when the appliance is disconnected from the energy supply.
- ✚  **CAUTION!** Even the temperature is less than 600 C there is RISK OF BURNS!

Locking the hob top

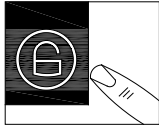

- ✓ The key lock sensor locks the appliance while switched on.
- ✓ The timer indicator indicates the symbol LO. □
- ✓ The enabled key lock function locks all sensors except the ON/OFF sensor. □
- ✓ Touch the key lock sensor again to disable the key lock function. The LO-symbol goes off.

The hob timer

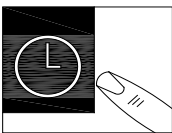

- ✓ The range of the timer is from 1 to 99 minutes. When the set time has elapsed you will hear an acoustic signal.
- ✓ Touch the timer sensor and set the time using the Plus/Minus sensors.
- ✓ The timer indicator indicates the set time.
- ✓ Each touch of the Plus/Minus sensors (5/6) increases/decreases the value by 1 minute. □
- ✓ If the value exceeds 99, the timer indicator will indicate 0.
- ✓ Touching the Plus/Minus sensors simultaneously will reset the timer indicator to 0.

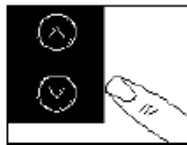

Safety cut-off

- ✓ If you have not switched off one or both cooking zones accidentally, the safety shutdown will be enabled after a particular period of time. The period of time depends on the set power level of the cooking zone(s).

LEVEL	TIME LIMIT (hours)
1-2	6
3-4	5
5	4
6-9	1.5

How to use the hot plate

The level of heat can be adjusted gradually by turning the appropriate knob to the right or left. Switching on the plate results in a green signal light on the control panel turning on.

An appropriately selected pan saves energy. A pan should have a thick, flat base with a diameter equal to the plate diameter as in that case is transferred most efficiently.



Caution!

- Ensure the heating plate is clean—a soiled zone does not transfer all of the heat.
- Protect the plate against corrosion.
- Switch off the plate against corrosion.
- Do not leave pans with prepared dishes based on fats and oils unattended on the switched-on plate; hot fat can spontaneously catch fire.

5. Hob guidelines

- ✧ The first few times the hob top is used, it may give off an acrid, burning smell. This smell will disappear completely with repeated use.
- ✧ The worktop is fitted with cooking areas of different diameter and power.
- ✧ The positions where the heat will radiate from are clearly marked on the hob top. The saucepans must be positioned exactly on these zones for efficient heating to occur. Pans should have the same diameter as the cooking zone that they are being used on.
- ✧ You should not use saucepans with rough bottoms, as this can scratch the ceramic surface.
- ✧ Before use, make sure that the bottoms of the saucepans are clean and dry.
- ✧ When cold, the bottom of the pans should be slightly concave, as they expand when hot and lie flat on the surface of the hob. This will allow the heat to transfer more easily.
- ✧ The best thickness for the bottom of the pans is 2 – 3 mm of enamelled steel and 4 – 6 mm for stainless steel with sandwich type bottoms.

- ✧ If these rules are not followed, then there will be a great loss of heat and energy. Heat not absorbed by the saucepan, will spread to the hob, frame and surrounding cabinets.
- ✧ Preferably cover pans with a lid to permit cooking at a lower heat.
- ✧ Always cook vegetables and potatoes, etc. in as little water to reduce cooking times.
- ✧ Food or liquid that has high sugar content may damage the hob top if it comes into contact with the ceramic hob surface. Any spillages should be wiped up immediately, however this may not prevent the hob surface from becoming damaged.
- ✚ **IMPORTANT:** The ceramic hob surface is tough; however it is not unbreakable and can be damaged. Especially if pointed or hard objects are allowed to fall on it with some force.

- ✚ **DO NOT USE THE HOB IF THE SURFACE BECOMES BROKEN OR CRACKED. YOU SHOULD SWITCH OFF THE APPLIANCE TO AVOID THE POSSIBILITY OF ELECTRIC SHOCK AND CONTACT THE BAUMATIC CUSTOMER CARE DEPARTMENT IMMEDIATELY.**

6. Maintenance and cleaning



Cleaning operations must only be carried out when the hob is cool.

The appliance should be disconnected from your mains supply before commencing any cleaning process.

Cleaning the ceramic hob top



Any residues that are left on the hob top surface from cleaning agents will damage it. You should remove any residues with warm water mixed with a little washing up liquid.



Abrasive cleaners or sharp objects will damage the hob surface; you should clean it using warm water mixed with a little washing up liquid.



You may find it easier to clean some deposits whilst the hob surface is still warm. However you should take care not to burn yourself if cleaning the hob surface when it is still warm.

After each use

- ◆ Wipe the appliance over with a damp cloth.

- ◆ Dry the appliance by rubbing the surface with a clean cloth.

Cleaning table

Type of deposit	Remove immediately?	Remove when the appliance has cooled down?	What should I use to remove the deposit?
Sugar or food/liquid containing sugar	Yes	No	Ceramic hob scraper
Tin foil or plastic	Yes	No	Ceramic hob scraper
Fat splashes	No	Yes	Ceramic hob cleaner
Metallic discolouration	No	Yes	Ceramic hob cleaner
Water splashes or water rings	No	Yes	Ceramic hob cleaner

Important!

The inside of the hob should only be washed with warm water and a small amount of washing-up liquid.

Caution!

Ensure the heating plate is clean-a soiled zone does not transfer all of the heat.

Protect the hob against corrosion.

Switch off the hob against corrosion.

Do not leave pans with prepared dishes based on fats and oils unattended on the switched-on plate; hot fat can spontaneously catch fire.



IMPORTANT: If your appliance appears not to be operating correctly, Please contact with dealer.

DO NOT ATTEMPT TO REPAIR THE APPLIANCE YOURSELF.

Please note that if an engineer is asked to attend whilst the product is under guarantee and finds that the problem is not the result of an appliance fault, then you may be liable for the cost of the call out charge.

The appliance must be accessible for the engineer to perform any necessary repair. If your appliance is installed in such a way that an engineer is concerned that damage will be caused to the appliance or your kitchen, then he will not complete a repair.

7. Environmental note

Note: Before discarding an old appliance, switch off and disconnect it from the power supply. Cut off and render any plug useless. Cut the cable off directly behind the appliance to prevent misuse. This should be undertaken by a competent person.

This appliance is marked according to the European directive 2002/96/EC on Waste electrical and Electronic Equipment (WEEE). By ensuring this product is disposed of correctly, you will help prevent potential negative consequences for the environment and human health, which could otherwise be caused by inappropriate waste handling of this product.

The symbol  on the product or on the documents accompanying the product indicates that this appliance may not be treated as household waste. Instead it shall be handed over to the applicable collection point for the recycling of electrical and electronic equipment.

Disposal must be carried out in accordance with local environmental regulations for waste disposal. For more detailed information about treatment, recovery and recycling of this product, please contact your local city office or local waste management office.

The packaging materials that we use are environmentally friendly and can be recycled. Please discard all packaging material with due regard for the environment.

