

COOKOLOGY

MICROWAVE OVEN INSTRUCTION MANUAL

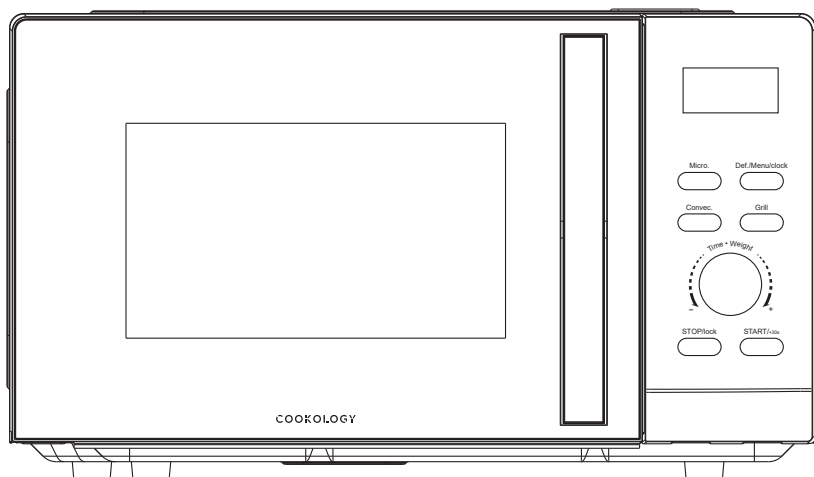

25L Combi Microwave- 900W
Model No.: FSMOG25LBK

**IMPORTANT SAFETY INSTRUCTIONS
READ CAREFULLY AND KEEP FOR FUTURE REFERENCE**

Please register the warranty for this product on www.Cookology.com

Household use only

SAVE THESE INSTRUCTIONS

IMPORTANT SAFEGUARDS

WARNING: If the door or door seals are damaged, the oven must not be operated until it has been repaired by a trained person.

WARNING: It is hazardous for anyone other than a trained person to carry out any service or repair operation, which involves the removal of any cover, which gives protection against exposure to microwave energy. **WARNING:** Liquids or other food must not be heated in sealed containers since they are liable to explode.

1. Only use utensils that are suitable for use in microwave ovens.
2. Metallic containers for food and beverages are not allowed during microwave cooking.
3. When heating food in plastic or paper containers, keep an eye on the oven due to the possibility of ignition.
4. The microwave oven is only intended for heating food and beverages. It is not recommended to dry food or clothing or warming pads, slippers, sponges, damp cloth and similar which may lead to the risk of injury, ignition or fire.
5. If smoke is observed, switch off or unplug the appliance immediately and keep the door closed in order to suppress any flames. Microwave heating of beverages can result in a delay for the liquid to boil, therefore take care when handling the container.
6. The contents of feeding bottles and baby food jars are to be stirred or shaken and the temperature is to be checked before consumption, in order to avoid burns.
7. Eggs in their shell and whole hard-boiled eggs shall not be heated in microwave ovens since they may explode, even after microwave heating has ended.
8. Failure to maintain the oven in a clean condition could lead to deterioration of the surface that could adversely affect the life of the appliance and possibly result in a hazardous situation.
9. The appliance must not be placed in a cabinet.

10. Care should be taken not to displace the turntable when removing containers from the appliance.
11. The appliance shall not be cleaned with a steam cleaner.
12. It is not recommended to install the appliance higher than 900mm above the floor. We recommend to sit the Microwave on a worktop securely fitted at the same level as a built-in cooking hob. Minimum height of free space necessary above the top surface of the oven: 100mm.

Warning: When the appliance is operated in the combination mode, children should only use the oven under adult supervision due to the temperatures generated.



CAUTION: HOT SURFACE

13. If the supply cord is damaged, it must be replaced by the manufacturer or its service agent or a similarly qualified person in order to avoid a hazard.
14. This appliance should not be used by children.
15. In order to avoid the internal glass plate from cracking, do not place it into cold water after use. We suggest allowing the glass plate to cool for 20 minutes before washing.
16. Group 2 Class B appliance
Class B equipment is suitable for use in domestic establishments and in establishments directly connected to a low voltage power supply network.
17. This product internal light source LED light on < 60lm.
18. After the Microwave has finished its cycle it will enter standby mode.
Standby power < 0.8W.

INSTALLATION

1. Remove all the transit packaging. Remove any film that may be covering the Microwave. . Check carefully for damage. If any, immediately notify the manufacturer.
2. Microwave ovens must be placed under dry and non-corrosive environments, keep away from heat and humidity as well as cooking hobs or ovens.
3. To ensure sufficient ventilation, the distance at the back of microwave to the wall should be at least 10 cm, the side to the wall should be at least 5 cm, the free distance above the top of the Microwave should be at least 10 cm.
4. The appliance must be positioned so that the plug is accessible and easy to disconnect if necessary.
5. The microwave oven must be operated with the door closed.
6. The microwave oven must not be placed in a cabinet. The microwave oven is intended to be used as freestanding appliance.
7. The first time the Microwave is used, It is recommended to place a cup of water in the Microwave and operating at high power for 2 minutes to clear any odours that may be present. Please repeat a few times to ensure the Microwave cavity is fresh.

CLEANING

MICROWAVE OVEN CARE

CAUTION

The oven should be cleaned regularly and any food deposits removed.

WARNING

- a. Remove the power cord from the wall outlet before cleaning. After cooling products. Don't immerse the appliance in water or other fluids when cleaning.
- b. Failure to maintain the oven in a clean condition could lead to deterioration of the surface that could adversely affect the life of the appliance and possibly result in a hazardous situation.
- c. Never use hard detergent, gasoline, abrasive powder or metal brush to clean any part of the appliance.
- d. Do not remove the waveguide cover.
- e. e. When the Microwave oven has been used for a long time, there may be some strange odours in oven, to clear please follow these two methods:
 - 1) Place several lemon slices in a cup, then heat with high micro power for 2-3 min.
 - 2) Put some orange peel into oven, and then heat with high micro power for 1 minute.change 'dampened' to 'damp' in all cases
- f. If the product is not being used, place it in a dry and well ventilated area.

WARNING

Details how to clean surfaces in contact with food:

After use wipe the waveguide cover with a damp cloth, followed by dry cloth to remove any food splashes and grease. Built-up grease may overheat and begin to cause smoke or catch fire.

TIPS FOR CLEANING

Details for cleaning door seals, cavity and adjacent parts:

Exterior:

Wipe the enclosure with a damp soft cloth

Door:

Using a damp soft cloth, wipe clean the door and window

Wipe the door seals and adjacent parts to remove any spill or spatter

Wipe the control panel with a slightly damp soft cloth **Interior**

walls:

Wipe clean the interior surfaces with a damp soft cloth Wipe clean the waveguide cover to remove any food splashed

Turntable / Rotation ring / Rotation axis:

Wash with mild soap water

Rinse with clean water and allow drying thoroughly

PRODUCT INSTRUCTION

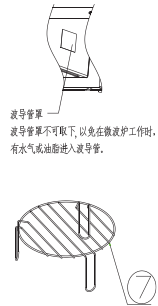
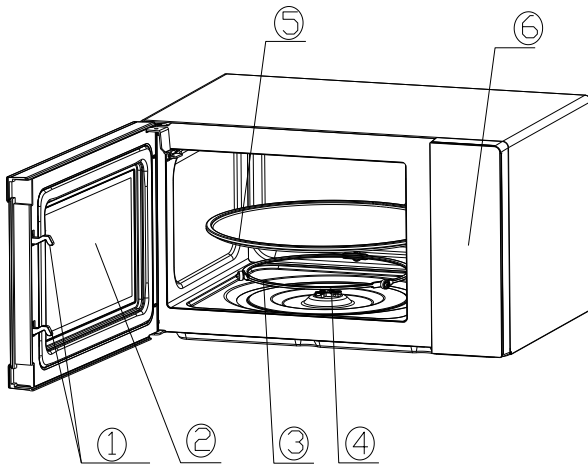

1) **Door lock**

Microwave oven door must be properly closed in order for it to operate

2) **Viewing window**

Allow user to see the cooking status

3) **Rotating axis**

The glass turntable sits on the axis; the motor underneath it drives the turntable to rotate

4) **Rotating ring**

The glass turntable sits on its wheels; it supports the turntable and helps it to balance when rotating

5) **Turntable**

The food sits on the turntable, its rotation during operation helps to cook food evenly

- Place the rotating ring first
- Fit the turntable onto the rotating axis and make sure that it is geared in properly

6) **Control panel**

See below in details (the control panel is subject to change without prior notice)

7) **Grill rack**

Use to place the roasting food.

8) **Housing**

It is used to wrap and protect the internal structural parts and electrical parts of the whole machine

9) **Waveguide cover**

It is inside the microwave oven, next to the wall of control panel.

Never remove the waveguide cover.

OPERATION OF CONTROL PANEL

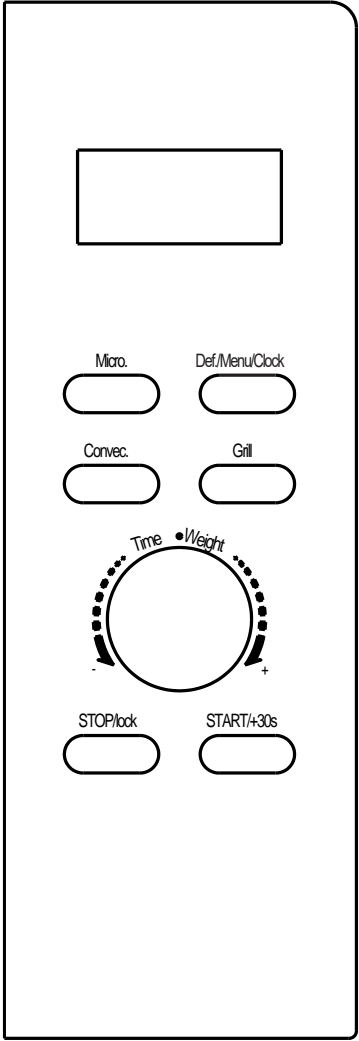

1. BEFORE COOKING

The display lights up when plugged in power supply, then enter the standby state and display shows 1:00.

2. MICROWAVE FUNCTION

There are five firepower levels, 100P, 80P, 50P, 30P and 10P, respectively. Press the “Microw.” button continuously to select the desired microwave power. Turn the knob to select cooking time, and the time range can be 0:10 ~ 60:00. After selecting the cooking time, press “START/+30s” button to start work. A buzzing sound to notify completion of the operation.

HIGH	100% power output	(Quick cooking)
M.High	80% power output	(Normal cooking)
Med	50% power output	(Slow cooking)
M.Low	30% power output	(Defrost food)
LOW	10% power output	(Keep warm)

- a. The max time which can be set is 60 minutes.
- b. Never use the grill rack during microwave cooking.
- c. Never operate the oven empty.
- d. At the maximum microwave power, the oven will automatically lower the power after a certain time of cooking to lengthen the service life.
- e. If you turn the food during operation, press the **Start/+30s** button once and the preset cooking procedure will continue.
- f. If you intend to remove the food before the preset time, you must press **Stop/Lock** button once to clear the preset procedure to avoid unintended operation of next time use.

3. DEFROST/MENU/CLOCK

Press DEF/MENU/CLOCK button to select 2 defrost functions and 8 menus. Press this button continuously to select the function sequence was as following: defrost by weight - defrost by time - A.1- A.2 - A.3 - A.4 - A.5 - A.6 - A.7- A.8, and cycle in turn.

3.1 DEFROST

There are two defrost mode, dEF1 and dEF2, respectively. dEF1 for defrost by weight and dEF2 for defrost by time. Press this button to select defrost by weight or by time, and the display screen will display "dEF1" or "dEF2". Turn the knob to select food weight or defrost time. The weight range of dEF1 is from 100 to 1500g, and the optional time range of dEF2 is from 0:10 to 60:00. After selecting the defrost weight or time, press the "START/+30s" button start to work. A buzzing sound to notify completion of the operation. The dEF1 defrost mode by weight will have a beeping sound to prompt the food to be turned over during defrosting.

Below is some food defrosting time advice:

dEF1	For defrosting, the weight range from 100 to 1500g.
dEF2	For defrosting, the time range from 0:10 to 60:00

- a. It is necessary to turn over the food during operation to obtain uniform effect.
- b. Usually defrosting will need longer time than that of cooking the food.

- c. If the food can be cut by knife, the defrosting process can be considered completed.
- d. Microwave penetrates around 4cm into most food
- e. Defrosted food should be consumed as soon as possible, it is not advised to put back to fridge and freeze again.

3.2 AUTO COOKING

There are eight automatic menus, Potato, Pasta, Pizza, Popcorn, Vegetable, Beverage, Meat and Fish respectively. Press the “DEF/MENU/CLOCK” button which to be selected continuously to select the desired menu and turn the knob to select the desired food weight, then press “START/+30s” button to start work. A buzzing sound to notify completion of the operation.

Display	Kind	Method
A.1	Potato	The optional weights are 250g, 500g and 750g.
A.2	Pasta	The optional weights are 50g, 100g and 150g.
A.3	Pizza	The optional weights are 200g and 400g.
A.4	Popcorn	The optional weight is 100g.
A.5	Vegetable	The optional weights are 200g, 400g and 600g.
A.6	Beverage	The optional weights are 1 cup, 2 cups or 3 cups, each one about 250ml.
A.7	Meat	The optional weights are 200g, 400g and 600g.
A.8	Fish	The optional weights are 200g, 400g and 600g.

- a. The temperature of food before cooking would be 20-25°C. Higher or lower temperature of the food before cooking would require increase or decrease of cooking time.
- b. The temperature, weight and shape of food will largely influence the cooking effect. If any deviation has been found to the factor noted on above menu, you can adjust the cooking time for best result.

3.3 CLOCK (24 hour)

In standby mode, press “DEF/MENU/CLOCK” button for more than 3 seconds to enter the clock setting interface. At the same time, the display screen blinks in hours. The hour time can be set by turning the knob. After setting the hour, press the "START/+30s" button for a short time to switch to the setting minute mode. The minutes can be set by turning the knob. After setting minutes, press the "START/+30s" button again to exit the setting mode.

4. GRILL FUNCTION

There are three modes of grill: G, G-1 and G-2. They are grill, combination 1 of grill and microwave cooking and combination 2 of grill and microwave cooking. Press the "Grill" button continuously, select the desired mode, and the display screen displays "G.", "G-1" or "G-2". Then, turn the knob to select the cooking time and the optional time range is 0:10 ~ 60:00. After selecting the cooking time, press the “START/+30s” button to start the work. A buzzing sound to notify completion of the operation.

G.	Grill, the heat element will be energized during operation time. Which is applicable for rolling thin meats or pork, sausage, chicken wing as good brown color can be obtained
G-1	Combination of grill and microwave cooking. 30% microwave and 70% grill.
G-2	Combination of grill and microwave cooking. 55% microwave and 45% grill.

In the mode of grill, all of the oven parts, as well as the rack and cooking containers, may become very hot. Use caution when removing any item from the oven. Use heavy potholders or oven mitts to PREVENT BURNS.

5. CONVECTION

There are three modes of convection: C, C-1 and C-2. They are convection, combination 1 of convection and microwave cooking and combination 2 of convection and microwave cooking. Press the "Convec." button continuously, select the desired mode, and the display screen displays "the set temperature", "C-1" or "C-2". Then, turn the knob to select the cooking time and the optional time range is 0:10 ~ 60:00. After selecting the cooking time, press the "START/+30s" button to start the work. A buzzing sound to notify completion of the operation.

C	Five temperature shifts can be set
C-1	Combination of convection and microwave cooking. 30% microwave and 70% convection.
C-2	Combination of convection and microwave cooking. 55% microwave and 45% convection.

In the mode of convection, all of the oven parts, as well as the rack and cooking containers, may become very hot. Use caution when removing any item from the oven. Use heavy potholders or oven mitts to PREVENT BURNS.

6. STOP

In the process of cooking settings, can press “STOP” button to cancel the settings and return to standby state. In the process of working, can press “STOP” button to pause. In the standby state, can press “STOP” button again to cancel the function and return to standby state.

7. START/+30s

After setting the cooking time or food weight, press “START/+30s” button to start microwave oven immediately. In working state, can press “START/+30s” button to increase time, press one time to increase 30 seconds, but the menu mode and weight defrosting mode can not adjust time. In pause state, can press “START/+30s” button to continue the microwave oven before cooking mode.

8. EXPRESS

In standby mode, after the food is put in and the door is closed, press the "START/+30s" button to quickly start the microwave. The default working time is 30 seconds. In the process of working, press the "START/+30s" button once for 30 seconds. A buzzing sound to notify completion of the operation.

9. CHILD LOCK FUNCTION

Use this feature to lock the control panel when you are cleaning or so that children can not use the oven unsupervised. All the buttons are rendered inoperable in this mode.

- 1) Set lock: Hold **STOP** button more than 3 seconds.
- 2) Cancel lock: Hold **STOP** button more than 3 seconds

UTENSILS GUIDELINE

It is strongly recommended to use the containers which are suitable and safe for microwave cooking. Generally speaking, the containers which are made of heat-resistant ceramic, glass or plastic are suitable for microwave cooking. Never use the metal containers for microwave cooking and combination cooking as spark is likely to occur. You can take the reference of below table.

Material of container	Microwave	Grill	Combi	Notes
Heat-resistant ceramic	Yes	Yes	Yes	Never use the ceramics which are decorated with metal rim or glazed
Heat-resistant plastic	Yes	No	No	Can not be used for long time microwave cooking
Heat-resistant glass	Yes	Yes	Yes	
Plastic film	Yes	No	No	It should not be used when cooking meat or chops as the over-temperature may do damage to the film
Grill rack	No	Yes	Yes	The grill rack can only be used in Grill mode.
Metal container	No	No	No	It should not be used in microwave oven. Microwave can not penetrate through metal.
lacquer	No	No	No	Poor heat-resistant. Can not be used for High-temperature cooking
Bamboo wood and paper	No	No	No	Poor heat-resistant. Can not be used for High-temperature cooking

COOKING TIPS

The following factors may affect the cooking result:

Food arrangement

Place thicker areas towards outside of dish, the thinner part towards the centre and spread it evenly. Do not overlap if possible.

Cooking time length

Start cooking with a short time setting, evaluate it after it times out and extend it according to the actual need. Over cooking may result in smoke and burns.

Cooking food evenly

Food such as chicken, hamburger or steak should be turned once during cooking.

Depending on the type of food, if applicable, stir it from outside to centre of dish once or twice during cooking

Allow standing time

After cooking times out, leave the food in the oven for an adequate length of time, this allows it to complete its cooking cycle and cooling it down in a gradual manner

Whether the food is done

Color and hardness of food help to determine if it is done, these include:

- Steam coming out from all parts of food, not just the edge
- Joints of poultry can be moved easily
- Pork or poultry shows no signs of blood
- Fish is opaque and can be sliced easily with a fork

Browning dish

When using a browning dish or self-heating container, always place a heat-resistant insulator such as a porcelain plate under it to prevent damage to the turntable and rotating ring.

Microwave safe plastic wrap

When cooking food with high fat content, do not allow the plastic wrap come into contact with food as it may melt

Microwave safe plastic cookware

Some microwave safe plastic cookware might not be suitable for cooking foods with high fat and sugar content. Also, the preheating time specified in the dish instruction manual must not be exceeded

MAINTENANCE

SERVICING

Please check the following before calling for services.

1. Place one cup of water (approx.150ml) in a glass measure in the oven and close the door securely. Oven lamp should go off if the door is closed properly. Let the oven work for 1 min.

2. Does the oven lamp light?

3. Does the cooling fan work?

(Put your hand over the rear ventilation openings.)

4. Does the turntable rotate?

(The turntable can rotate clockwise or counter clockwise. This is quite normal.)

5. Is the water inside the oven hot?

If “NO” is the answer to any of the above questions, please check your wall socket and the fuse in your meter box.

If both the wall socket and the fuse are functioning properly, CONTACT YOUR NEAREST SERVICE CENTER APPROVED.

SERVICING SAFEGUARDS- IMPORTANT TRAINED PERSONNEL ONLY

The following are notes to assist Service engineers

Caution: MICROWAVE RADIATION

1. The high voltage capacitor remains charge after disconnection; short the negative terminal of H. V capacitor to the oven chassis (use a screwdriver) to discharge before touching.

2. During servicing below listed parts are liable to be removed and give access to potentials above 250V to earth.

- Magnetron
- High voltage transformer
- High voltage capacitor
- High voltage diode
- High voltage fuse

3. The following conditions may cause undue microwave exposure during servicing.

- Improper fitting of magnetron;
- Improper matching of door interlock, door hinge and door;
- Improper fitting of switch support;
- Door, door seal or enclosure has been damaged.

Correct Disposal of this product



This marking indicates that this product should not be disposed with other household wastes throughout the EU. To prevent possible harm to the environment or human health from uncontrolled waste disposal, recycle it responsibly to promote the sustainable reuse of material resources. To return your used device, please use the return and collection systems or contact the retailer where the product was purchased. They can take this product for environmental safe recycling.